



Alloy steel, nickel-plated, welding-sealed.
Suitable for floor scales, hopper scales and other electronic weighing devices.

Weighing Assembly Available- See the details on page 81, 82, 84, 85, 86, 88 and 89.

Capacity	Accuracy	Part number
0.5t	C3	HM8C-C3-0.5t-4B
1.0t	C3	HM8C-C3-1.0t-4B
1.5t	C3	HM8C-C3-1.5t-4B
2.0t	C3	HM8C-C3-2.0t-4B
3.0t	C3	HM8C-C3-3.0t-4B
5.0t	C3	HM8C-C3-5.0t-4B
10t	C3	HM8C-C3-10t-4B

Specifications

Accuracy Class	C3	Temperature effect on zero (%FS/10°C)	0.02
Rated output (mV/V)	2.0±0.004	Temperature, Compensated (°C)	-10~+40
Combined error (%FS)	0.02	Temperature, Operating (°C)	-35~+65
Non-linearity (%FS)	0.02	Excitation, Recommended (V)	5~12(DC)
Non-repeatability (%FS)	0.01	Excitation, Max. (V)	18(DC)
Creep (%FS/30min)	0.02	Safe Overload (%FS)	120
Input Resistance (Ω)	350±3.5	Ultimate Overload (%FS)	150
Output Resistance (Ω)	350±3.5	Protection Class	IP 68
Insulation Resistance (MΩ)	≥5000(50VDC)	Cable Length (m)	4(0.5-2t), 6(3-10t)
Zero Balance (%FS)	1.0	Cable spec	4-wire shielded PU cable
Temperature effect on span (%FS/10°C)	0.02		

Connections Red Input(+) Black Input(-) Green Output(+) White Output(-) Transparence (Shield)

Outline Dimensions in mm(inches)

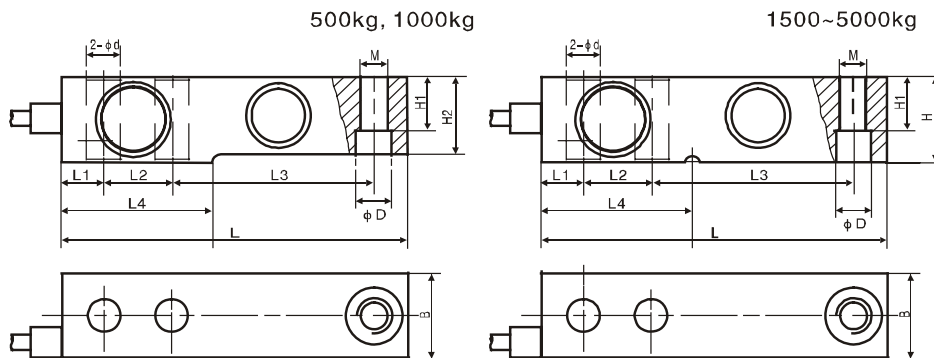

Capacity(t)	L	L1	L2	L3	H	B	D	M	L4	H1	H2
0.5	130 (5.12)	15.8 (0.62)	25.4 (1.00)	76.2 (3.00)	31.8 (1.25)	31.8 (1.25)	13.5 (0.53)	M12X1.75	53.7 (2.11)	15.8 (0.62)	26 (1.02)
1.0	130 (5.12)	15.8 (0.62)	25.4 (1.00)	76.2 (3.00)	31.8 (1.25)	31.8 (1.25)	13.5 (0.53)	M12X1.75	53.7 (2.11)	15.8 (0.62)	28 (1.10)
1.5-2	130 (5.12)	15.8 (0.62)	25.4 (1.00)	76.2 (3.00)	31.8 (1.25)	31.8 (1.25)	13.5 (0.53)	M12X1.75	54.2 (2.11)	15.8 (0.62)	/
3-5	171.5 (6.75)	19.1 (0.75)	38.1 (1.50)	95.3 (3.45)	38.1 (1.50)	38.1 (1.50)	19.8 (0.78)	M18X1.5	77.2 (3.04)	18.8 (0.74)	/
10	223 (8.75)	25.4 (1.00)	50.8 (2.00)	120.7 (4.75)	50.8 (2.00)	50.8 (2.00)	26 (1.02)	M24X2	101.6 (4.00)	25.4 (1.00)	/